

WALL MOUNT BACK PLATE HINGE

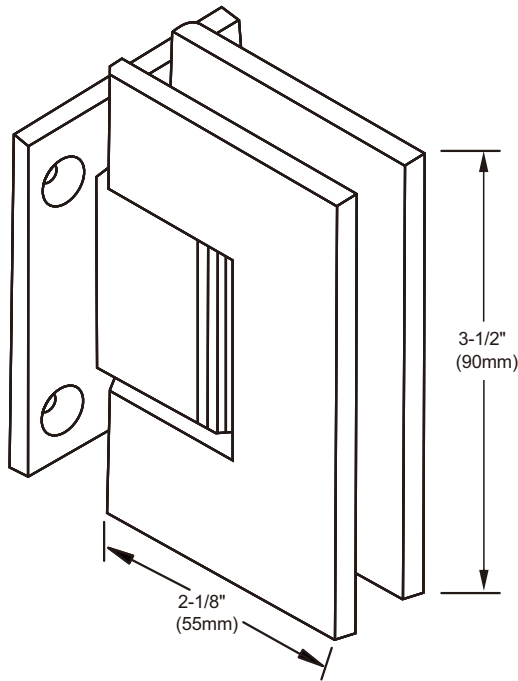

SPECIFICATIONS

For 8mm (5/16") to 12mm (1/2") glass
 -use 2 hinges, having a maximum weight of 80 lbs (36kg), and a width of 28"(711mm).
 -use 3 hinges, having a maximum weight of 120 lbs (54kg), and a width of 32" (813mm).

CAUTION

For public safety, we recommend only using tempered or safety glass.
 (But verify with local building codes.)

DO NOT USE POWER TOOLS FOR MOUNTING THESE HINGES

CLEANING

See reverse side for instructions

*Maximum Door Capacities	5/16"(8mm) and 3/8"(10mm) Glass weight width	1/2" (12mm) Glass weight width
Using 2 Hinges	80lbs.(36kg) 28"(711mm)	80lbs.(36kg) 28"(711mm)
Using 3 Hinges	120lbs.(54kg) 32"(813mm)	120lbs.(54kg) 32"(813mm)

*NOTE: Do not exceed either maximum weight or width when choosing proper quantity of hinges

WALL MOUNT BACK PLATE HINGE

ALWAYS USE DIMENSIONS



TO ENSURE ACCURACY

